

Counter Top Heated Merchandisers

HOTT1

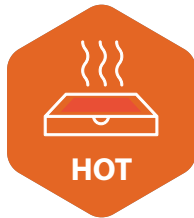

HOTT1

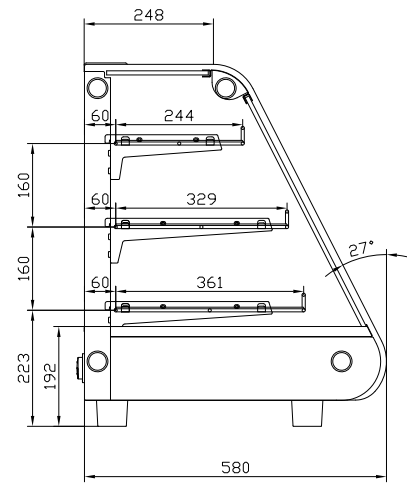

HOTT2

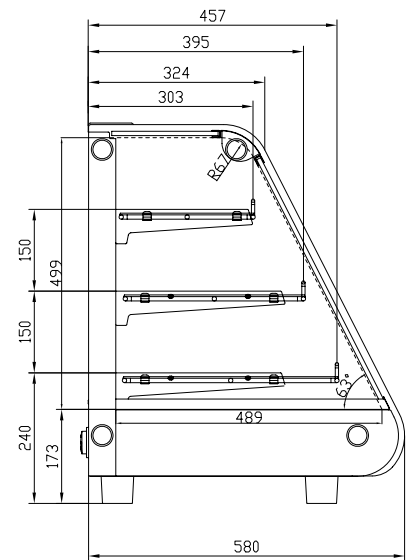

FEATURES

- Rear sliding doors, easily removable for cleaning
- 3 removable chrome plated shelves
- Internal humidity pan
- LED illumination with on/off switch

TECHNICAL SPECIFICATIONS

- Controller: Digital controller with temperature display on service side
- Temperature Range: +30°C ~ +90°C
- Power Supply: 13amp

MODEL	FINISH	GROSS CAPACITY	EXT. DIMENSIONS (H x W x D mm)	POWER CONSUMPTION	DECIBELS	WEIGHT (kg)	RRP
HOTT1	Stainless steel construction	130L	698 x 678 x 580	1100W	40-75dBA	47	
HOTT2		160L	698 x 856 x 580	1500W	40-75dBA	52	

