

# Crystallite Island Display Freezers

**CRYSTALLITE15**

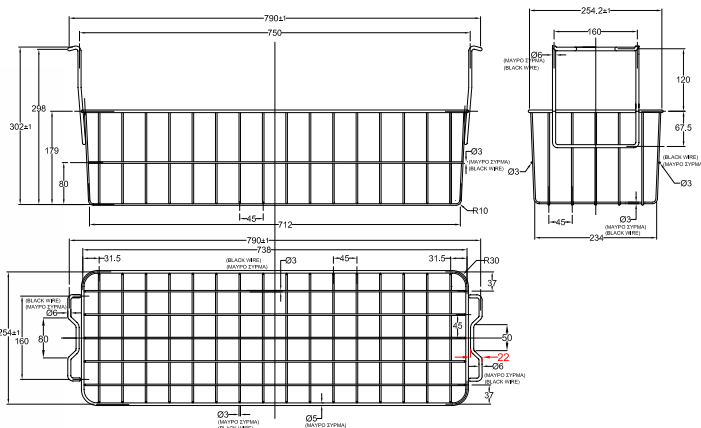

**CRYSTALLITE25**

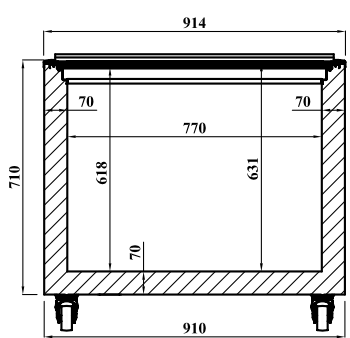

## FEATURES

- Pre-painted white steel exterior & interior
- Single glazed sliding glass lids
- 75mm castors fitted as standard ( 2 lockable)
- Bumper bars fitted as standard
- Crystallite 20 & 25 have two compartments
- Optional baskets and dividers

## TECHNICAL SPECIFICATIONS

Controller:	Manual thermostat with analogue temperature display
Cooling:	Static
Defrost:	Manual
Refrigerant:	R290
Climate Class:	4
Temperature Range:	-18°C ~ -26°C
Power Supply:	13amp

MODEL	GROSS CAPACITY	BASKET CAPACITY	EXT. DIMENSIONS (H x W x D mm)	POWER CONSUMPTION	DECIBELS	WEIGHT (kg)	RRP
CRYSTALLITE 15	600L	5	840 x 1554 x 914	376W	52dBA	132	
CRYSTALLITE 20	797L	6	840 x 2004 x 914	407W	55dBA	149	
CRYSTALLITE 25	1038L	8	840 x 2504 x 914	517W	50dBA	181	
Crystallite Basket	-	-	-	-	-	-	
Crystallite Divider	-	-	-	-	-	-	

